



AN

ANGULAR HEADS CUTTING UNIT

切割装置

AÇILI KAFA KESME ÜNİTELERİ



THE E-MOTORS
COMPETENCE LEADER

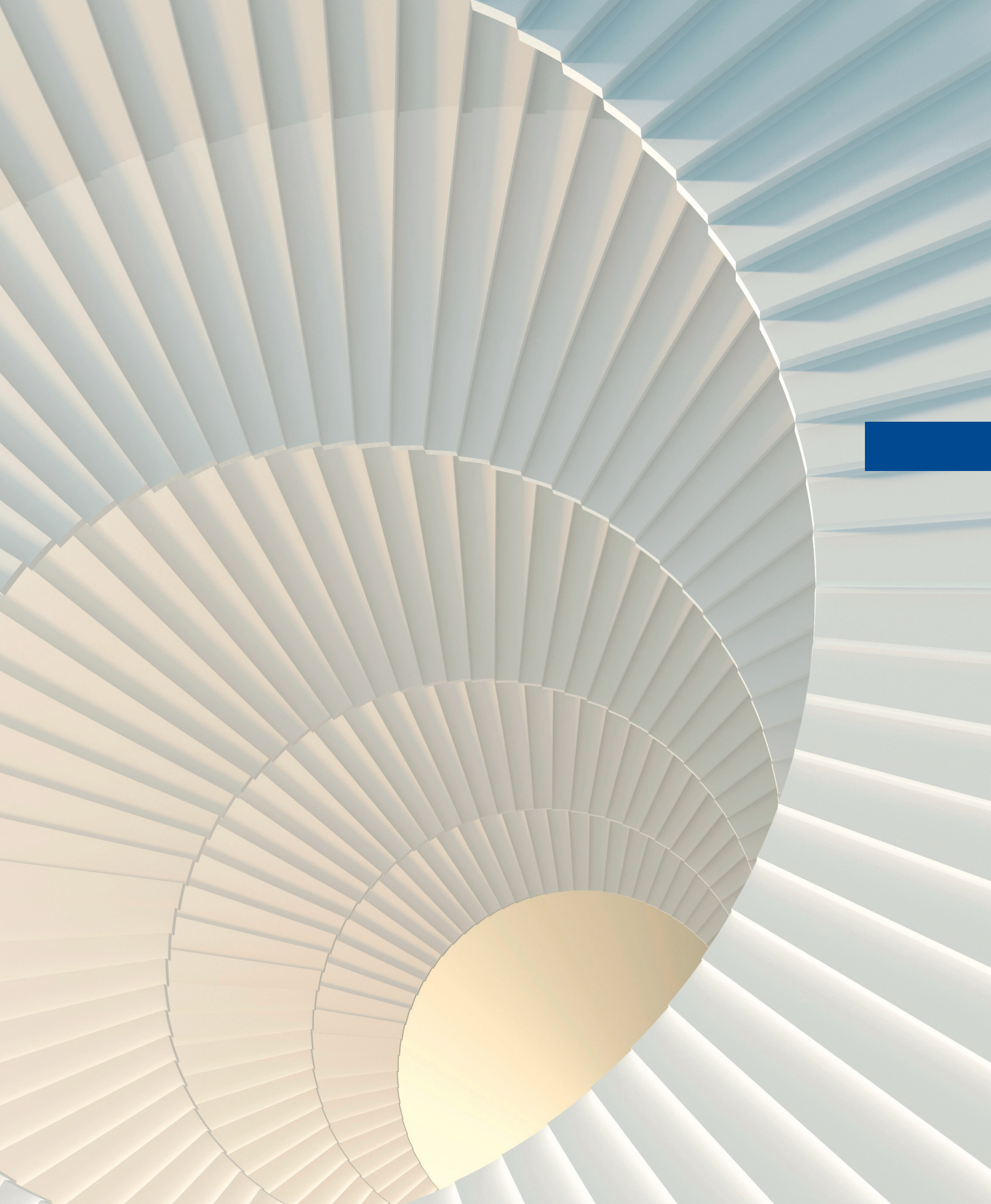



THE E-MOTORS
COMPETENCE LEADER

SACCARDO2.0

THE NEVER ENDING QUALITY ERA

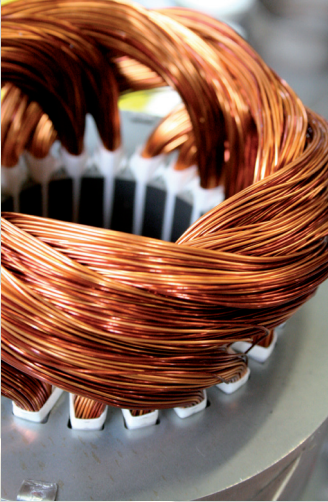

50 YEARS EXPERIENCE PROJECTED TOWARDS A SUCCESSFUL FUTURE

The ability to compare their wealth of experience with changing market demands, to be open to cooperation of co- design with other industrial realities, to develop lead technology, is the secret of a success remains strong over time Together for a future of rewards

50多年的历史达到成功的未来
依靠自有的丰富经验来满足市场的不同要求、研发最先进之
技术、开通企业合作开发产品使我公司维持成功之现状
与大家一起创造成功的未来

BAŞARILI BİR GELECEĞE DOĞRU 50 YILLIK DENEYİM

Zamana meydan okuyan başarının sırrı; değişen pazar talepleri ile şirketin deneyim zenginliğini karşılaştırma, diğer endüstriyel gerçeklerle ortak tasarım işbirliğine açık olma ve öncü teknoloji geliştirme becerisidir. Kazançlı bir gelecek için hep birlikte

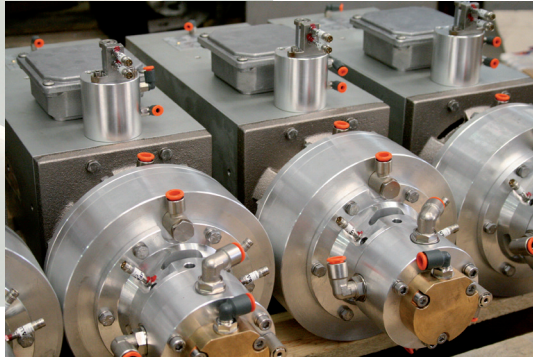
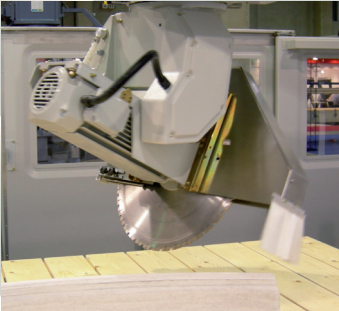

Overall and fitting dimensions

体积和产品使用时外形尺寸/Boyutsal ve bağlama özellikleri

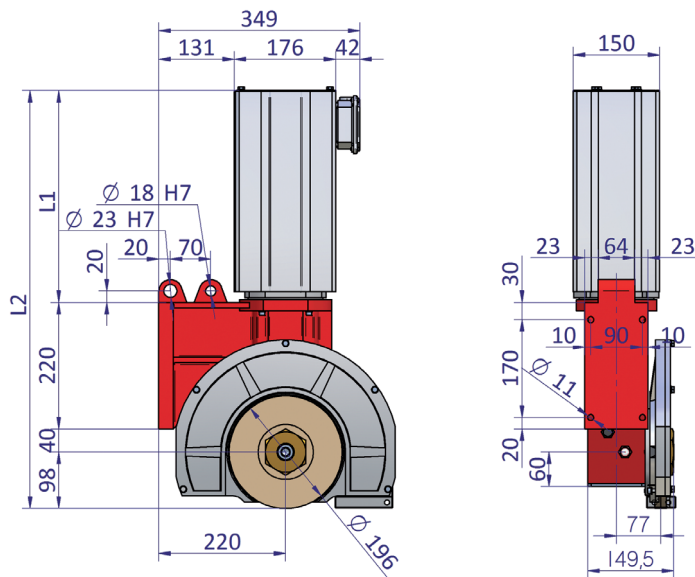

AN 01 - motor/motor SL
AN 01款-SL型电机

	AB	CDEFG
L1	369	454
L2	727	812

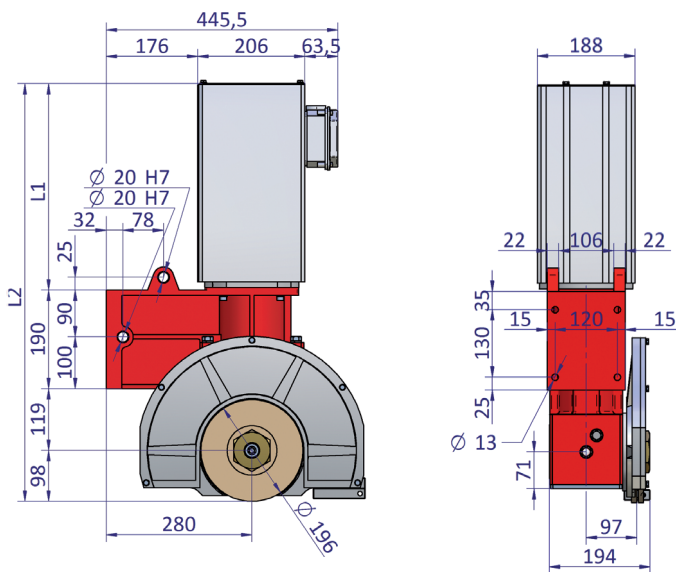

AN 02 - motor/motor SL
AN 02款-SL型电机

	ABG	CHIO
L1	398	448
L2	805	855

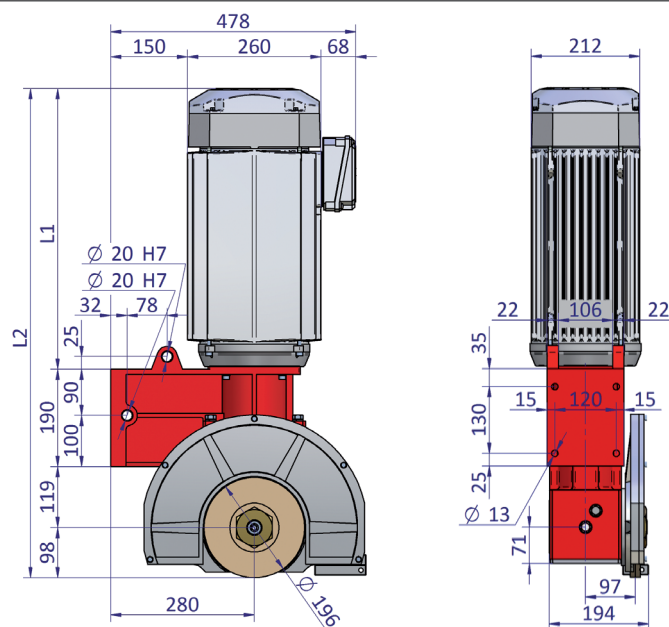

AN 02 - motor/motor SBC
AN 02款-SBC型电机

	DELMQRS
L1	548
L2	955

400 V / 50 Hz

Rated data/额定数据/Nominal veriler

Motor Type 电机类型 Motor tipi	Service S1 S1工作制 Hizmet S1				Service S6 S6工作制 Hizmet S6			Service S9 S9工作制 Hizmet S9			kg 公斤 kg	Motor 电机 Motor
	(kW)	(Cv)	(A)	(rpm)	(kW)	(Cv)	(A)	(kW)	(Cv)	(A)		
AN01A	3,3	4,5	7,4	2850	3,9	5,5	8,5	4,3	5,8	9,4	63	SL
AN01B	4,2	5,8	9,3	2855	4,9	6,8	11,1	5,5	7,5	12,2	65	SL
AN01C	4,7	6,5	10,4	2860	5,6	7,5	12,6	6	8,2	13,1	69	SL
AN01D	5	6,8	10,9	2865	5,9	8	12,9	6,3	8,5	13,7	71	SL
AN01E	3,1	4,3	8	1405	3,7	5	9,5	4	5,5	10,5	64	SL
AN01F	4	5,5	10,9	1415	4,9	6,6	12,5	5,2	7	13,2	68	SL
AN01G	3,3/4,4	4,5/6	8,1/9	1410/2855	4/5,3	5,5/7,1	9,2/11	4,3/5,7	5,8/7,8	9,5/12,2	70	SL

400 V / 50 Hz

Rated data/额定数据/Nominal veriler

Motor Type 电机类型 Motor tipi	Service S1 S1工作制 Hizmet S1				Service S6 S6工作制 Hizmet S6			Service S9 S9工作制 Hizmet S9			kg 公斤 kg	Motor 电机 Motor
	(kW)	(Cv)	(A)	(rpm)	(kW)	(Cv)	(A)	(kW)	(Cv)	(A)		
AN02A	5,6	7,5	11,9	2870	6,6	9,1	14,3	7,3	9,8	15,3	93	SL
AN02B	8	10,9	17	2870	9,5	12,8	20,3	10,5	14,3	22,3	95	SL
AN02C	10	13,6	21,2	2870	11,8	16	25	13	17,5	27,2	98	SL
AN02D	11,2	15,2	23,6	2900	12,5	17	26,8	14,5	19,5	30,4	128	SBC
AN02E	15	20,4	28,2	2910	18	24,3	33,5	19,5	26,5	37,5	148	SBC
AN02G	4,7	6,5	10,6	1405	5,5	7,5	12,4	6	8,2	13,5	98	SL
AN02H	6,3	8,6	13,7	1425	7,5	10	16,5	8,2	11	18,2	100	SL
AN02I	9,0	12,2	19	1425	11	15	23,5	12	16,5	26	103	SL
AN02L	9,5	12,9	20,3	1425	11	15	24	12	16	26	135	SBC
AN02M	11	15,2	24,2	1430	13	17,5	28,5	14,3	19,5	31,5	144	SBC
AN02O	5,3/7,5	7,2/10,2	11,2/15,8	1410/2870	6/8,5	8,2/11,6	13,5/19	6,7/9	9,1/12,2	15,7/21,1	98	SL
AN02Q	9/11,2	12,2/15,2	19/23,5	1420/2870	10/12,5	13,5/17	22/28	11,2/14	15,2/19	24,3/30,6	135	SBC
AN02R	13,0	17,5	28,4	1430	15,5	21	34,5	17	23	37	153	SBC
AN02S	14,6	20	30	1430	16,5	22,5	36,8	18,5	25	40	162	SBC

Other electrical details available on demand

请于工厂联系得到跟多的数据

Talep üzerine temin edilen diğer elektrik özellikleri

Technical details

技术特性/Teknik özellikler

Standard equipment: flanges and locking nut, protection guard, water injector and bushes
标准配套产品: 法兰盘、螺母、刀片安全外壳、轴套(多刃刀圈)、注水器
Standart donanım: flanşlar ve somun, koruma karteri, su enjektörü ve kovanlar

Maximum applicable disc: AN01 Ø 350 mm, AN02 Ø 400 mm.

最大可装的刀片: 直径350MM AN01款, 直径400MM, AN02款

Uygulanabilir maksimum disk: AN01 Ø 350 mm, AN02 Ø 400 mm.

Standard gear ratio: AN01 1:1, AN02 1:1 o 1:1,5

下刀频率 (切割周期): AN01款 1:1, AN02款 1:1 或 1:1,5

Standart dişli oranı: AN01 1:1, AN02 1:1 veya 1:1,5

Blade hole: Ø 50 mm.

刀片接口直径: 50 mm.

Bıçak deliği: Ø 50 mm.

Recommended oil: Mobil Gear 630 or correspondent

推荐的润滑油: Mobil Gear 630 或相同的

Tavsiye edilen yağ: Mobil Gear 630 veya benzeri

Custom execution and technical assistance

特殊使用定制和维修服务

Özel uygulamalar ve teknik servis

Optional

其他/Opsiyonel

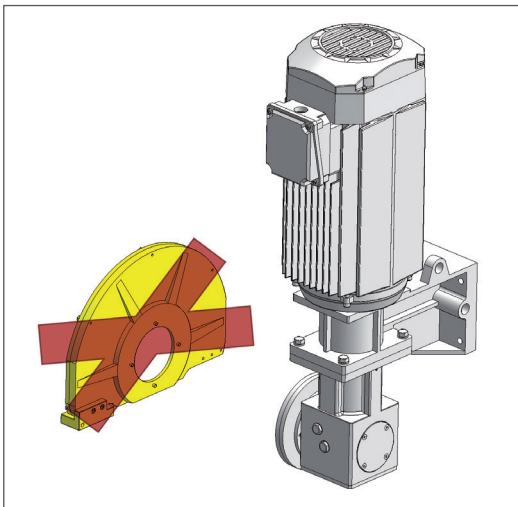

Without protection guard

无安全外壳

Kartersiz

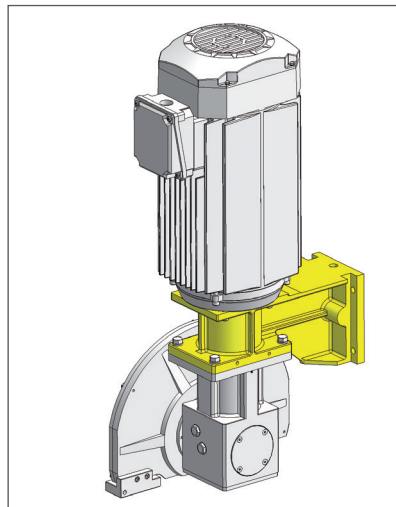

Customized support

C A D图定制刀体支撑

Özelleştirilmiş destek

Features

特别配制/Konfigürasyonlar

A. Left execution/逆时针转动/Sol uygulama

The saw blade turns right and srew thread is left
 顺时针刀片，逆时针性螺母
 Disk sağa döner ve vida dişi soldadır

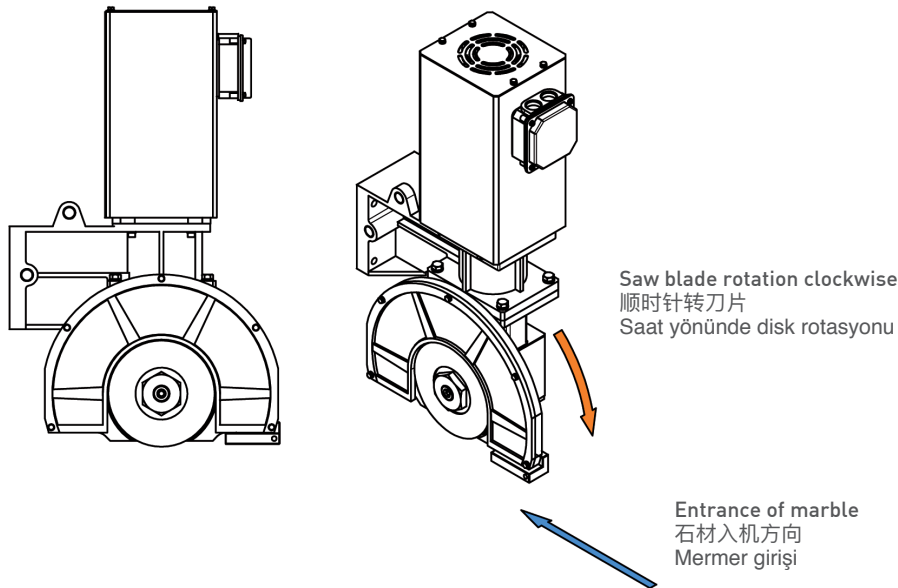

B. Right execution/顺时针转动/Sağ uygulama

The saw blade turns left and srew thread is right
 逆时针刀片，顺时针性螺母
 Disk sola döner ve vida dişi sağdadır

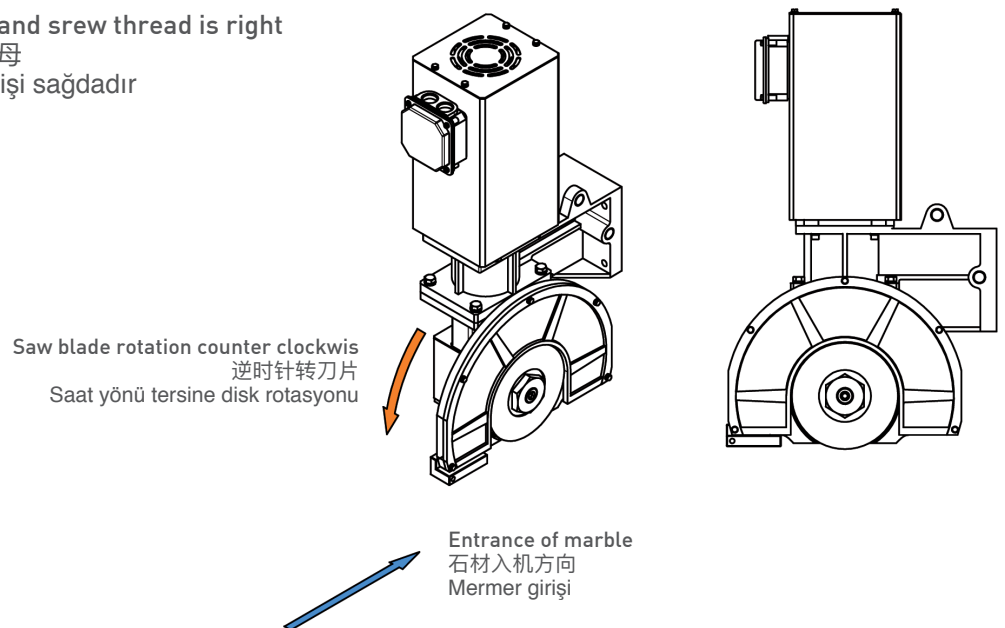

The specifications of the motors included in this catalogue are indicative, Saccardo Elettromeccanica reserves the right to introduce, without notice, changes to the componens, where deemed necessary, in order to improve the quality of the motor, according to the technical know-how acquired and to the present state of art.
 本手册的电机参数仅供参考，SACCARDO 公司有权保留在必要时对组件进行任何修改的权利，无需事先通知
 İşbu katalogta bulunan motorların özellikleri örnek niteliğindedir; Saccardo Elettromeccanica firmasının, edinilen teknik bilgilere ve teknolojinin bugünkü durumuna göre motorun kalitesini iyileştirmek amacıyla gerekli addettiği çerçevede, önceden haber vermeksizin komponentlerde değişiklik yapma hakkı saklıdır.



THE E-MOTORS
COMPETENCE LEADER

Saccardo Elettromeccanica S.r.l.
Via Casa celeste, 10
36014 Santorso VI. ITALY
tel.: +39 0445 540542 - fax: +39 0445 540538
www.saccardo.it - info@saccardo.it

中国总代理
安德鲁信重工江苏有限公司

地址：江苏省江阴市澄江东路3号
手机：18961619099
邮箱：info@andrewen.com
网址：www.andrewen.com